

EURODLT

SOFTENERS USER AND INSTALLATION MANUAL

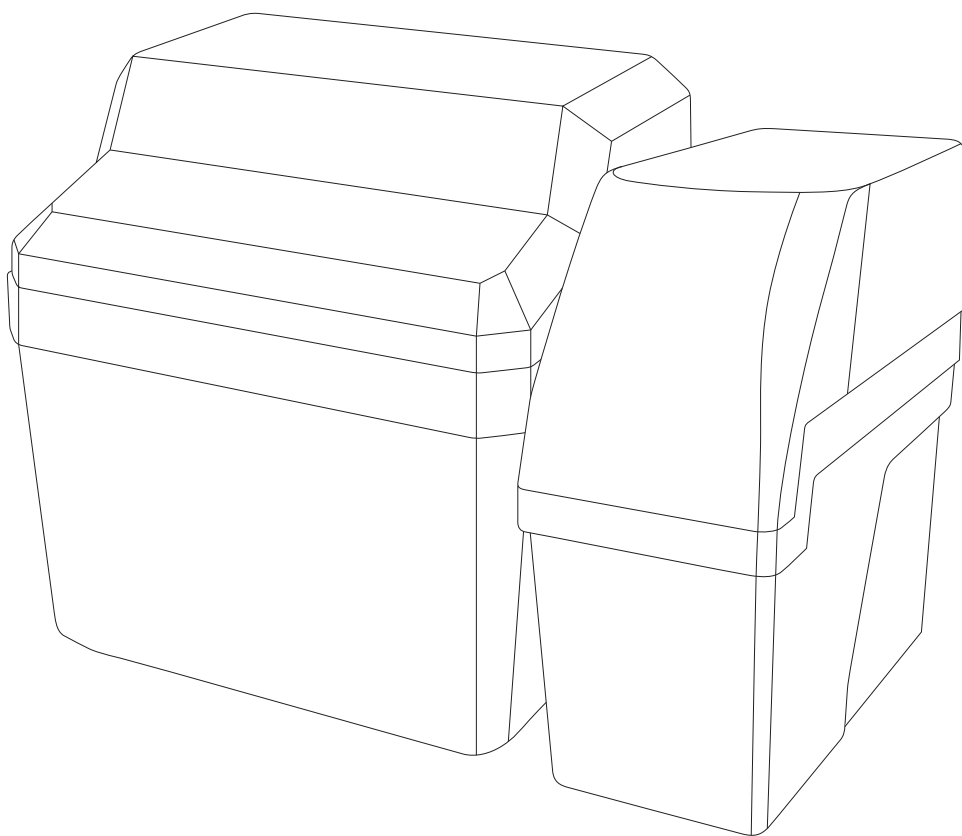

TABLE OF CONTENTS

DECLARATION OF CONFORMITY	p. 4
DESCRIPTION OF THE EURODLT SOFTENER	p. 6
DLT54A - DLT56A TECHNICAL DATA	p. 7
CONTROL HEAD + VALVE BODY	p. 8
THE BRINE VALVE	p. 9
BRINE VALVE POSITION IN THE CONTAINER	p. 10
BRINE VALVE POSITION IN THE CONTAINER	p. 11
DRAIN PIPES CONNECTION	p. 11
BRINE PIPES CONNECTION	p. 12
COMMUNICATION PIPES CONNECTION	p. 12
BY-PASS	p. 13
ADJUSTMENT OF RESIDUAL HARDNESS	p. 13
INSTALLATION LOCATION	p. 14
PREPARING THE SOFTENER FOR THE FIRST REGENERATION	p. 15
INLET WATER HARDNESS ADJUSTMENT	p. 16
TOP VIEW OF THE CONTROL HEAD	p. 16
DLT56A INSTALLATION WITH BY-PASS	p. 17
INSTALLATION OF DLT56A TO AN EXTERNAL BY-PASS SYSTEM	p. 18
INSTALLATION OF DLT54A	p. 19
BEGINNING OF A REGENERATION	p. 20
DISINFECTION WITH CITRIC ACID	p. 21
PIPE CONNECTION/DISCONNECTION	p. 22
MAINTENANCE MANUAL	p. 23
WARRANTIES	p. 23

Dear Customer, Thank you for choosing this EurodlT product, manufactured in Italy.



ATTENTION: this equipment requires regular periodic maintenance in order to ensure the potability requirements of treated drinking water and the maintenance of improvements as declared by the manufacturer.

DECLARATION OF CONFORMITY

The equipment indicated in this installation, user and maintenance manual of the series

DLT54A - DLT56A Softeners

complies with the following Laws:

- M.D. 25/2012** Technical requirements in equipment to treat water intended for human consumption.
M.D. 174/04 Regulation concerning the materials and objects that can be used in fixed collection, treatment, supply and distribution systems of water intended for human consumption.
PD 59/2009 Regulation on energy efficiency in construction.

IMPORTANT NOTES ON USING THE EURODLT SOFTENERS

The EURODLT softeners must be kept protected from frost, the environment temperature must not be less than 5°C and the inlet water temperature must not exceed 50°C.

The inlet water must be free of or below the acceptable values of substances that can damage its functionality:

- Strong oxidisers (NaOCl sodium hypochlorite, H2O2/O3 Hydrogen peroxide, CH3-CO2H Acetic acid, KMnO4 Potassium permanganate).
- Colloids and non-soluble substances in the water under 80 microns.
- Oils, lubricants, hydrocarbons, organic solvents.
- The concentrations of the oxidising substances and their relative elements must not exceed 0.5 ppm in the water (e.g. NaOCl Sodium Hypochlorite).
- The total hardness must not exceed 75°f and the total dissolved solids (TDS) 1000 ppm of ions (sand, earth, various impurities, etc.).
- The total concentration of iron must not exceed 0.5 ppm.
- The micro-organisms and biological activity must be strictly controlled so that the potential pollution does not exceed the alarm threshold.

The EURODLT softeners must be protected against possible hydraulic pressure water-hammers. If the supply water pressure (mains water) exceeds 5 bar (static pressure), install a pressure reducer. The inlet mains water pressure must be at least 2 bar (dynamic pressure) to maintain proper operation. If the system is equipped with an electric pump or autoclave to supply or maintain the water pressure, always install an adequate anti-water hammer device. As for systems with hot water storages (puffer, boiler, etc.), make sure that the expansion vessels are sufficient and working properly to avoid overpressures dangerous for the softener.

Always open the water supply valve gently.

Declaration of Potability Parameters (Italian Legislative Decree 31 of 02/02/2001), which are modified (improved) by the appliance.

The EURODLT series softeners modify the following water potability parameters: all positive ions (cations) and, in particular, Calcium, Magnesium, Sodium.

Indication of Disposal Mode

After the EURODLT appliance has been used, proceed with disposal according to current local and national regulations by using the designated CER code.

DESCRIPTION OF THE EURODLT SOFTENER

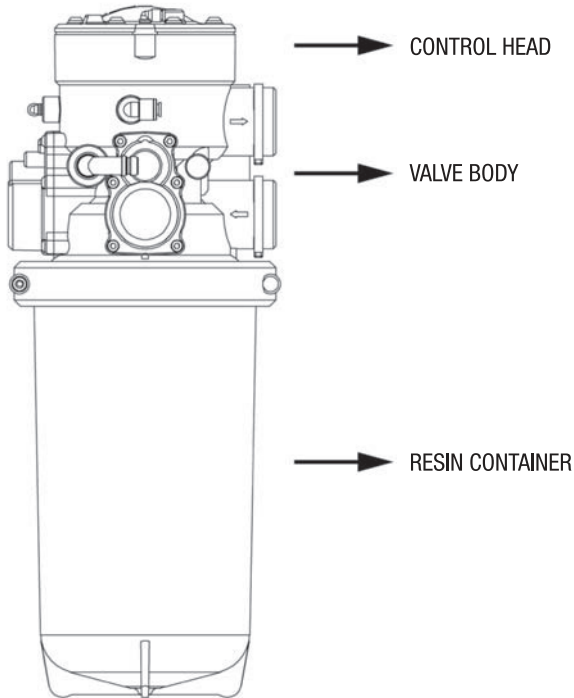

DLT54A TECHNICAL DATA [mm]

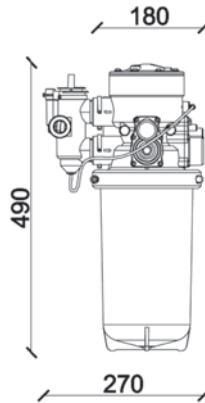
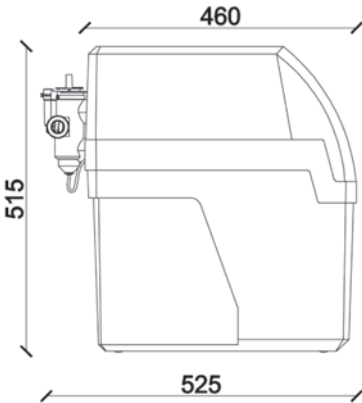

Fitting.....1" or 3/4"
 Recommended pressure reducer.....3/4"
 Max water temperature.....50°C
 Mini-maxi pressure.....2-6 bar
 Peak flow rate.....1,500 l/h
 Service flow rate.....1,000 l/h
 Head loss.....0.5 bar

Exchange capacity.....16.64 m³/f
 Resin volume.....3.2 l
 Water used for the regeneration.....from 16 to 25 l
 Salt used for the regeneration.....0.300 kg
 Regeneration time.....15 minutes
 Dimensions (l x d x h).....230 x 525x 515 mm
 Capacity of the salt vat.....11 kg

DLT56A TECHNICAL DATA [mm]

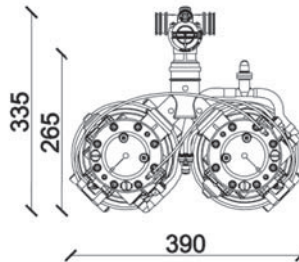
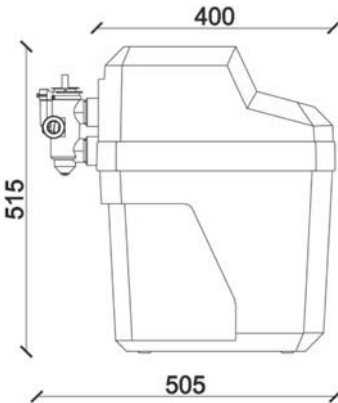

Fitting.....1" or 3/4"
 Recommended pressure reducer.....≥ 3/4"
 Max water temperature.....50°C
 Mini-maxi pressure.....2-6 bar
 Peak flow rate.....3,000 l/h
 Service flow rate.....2,000 l/h
 Head loss.....0.5 bar

Exchange capacity.....2 x 16.64 m³/f
 Resin volume.....2 x 3.2 l
 Water used for the regeneration.....from 2 x 16 to 2 x 25 l
 Salt used for the regeneration.....2 x 0.300 kg
 Regeneration time.....2 x 15 minutes
 Dimensions (l x d x h).....480 x 505x 515 mm
 Capacity of the salt vat.....35 kg

CONTROL HEAD + VALVE BODY

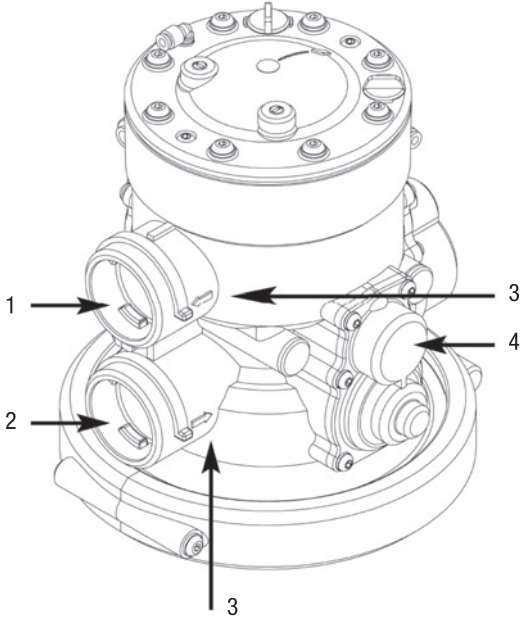

REAR - LEFT VIEW

1. Softened water outlet
2. Mains water inlet
3. Water direction arrows
4. Valve 2

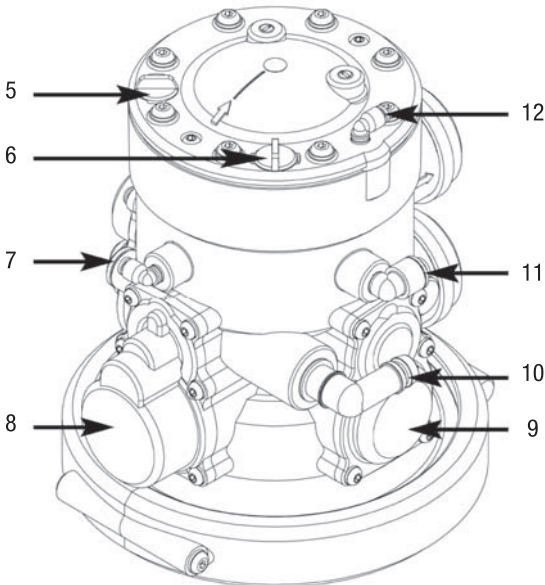

FRONT - RIGHT VIEW

5. Cap for left leakage controller
6. Cap for right leakage controller
7. Water pipe fitting for:
 - DLT56A duplex communication
 - signal to by-pass in DLT54A
8. Valve 1/3
9. Venturi seat
10. Drain pipe outlet
11. Connection pipe to the brine valve
12. Inlet pipe for communication in DLT56A duplex

THE BRINE VALVE

All EURODLT softeners are equipped with a brine valve.

The brine valve is a vital element for the proper operation of the softener and must be correctly positioned in its seat in the brine container.

The brine valve must always be separated from the salt to prevent salt pieces obstructing the closure of the brine valve at the gasket (6).

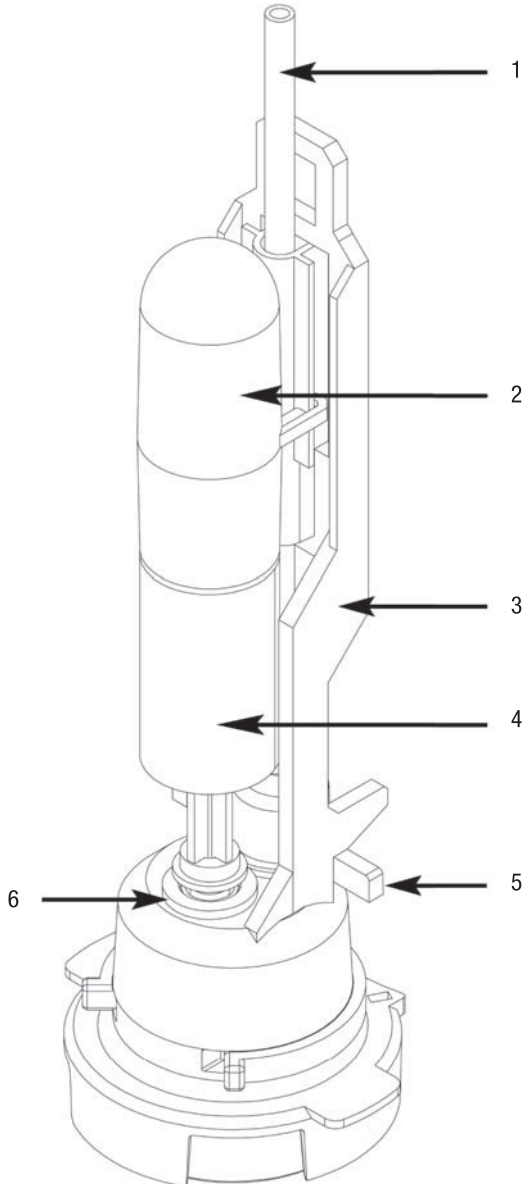

1. Ø6 Connection pipe
2. Float
3. Brine valve body
4. Float for DLT54A
5. Pipe-stop quick fitting
6. Gasket

BRINE VALVE POSITION IN THE CONTAINER

DLT54A

In the DLT54A model the brine valve is located on the salt separator (1) that slides into the groove inside the brine container. Make sure that the brine valve is firmly secured (2).

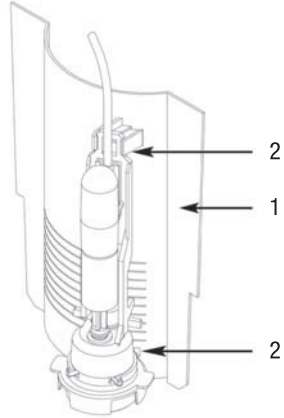
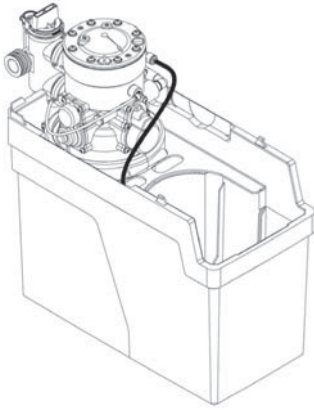

DLT56A

In the DLT56A model, the brine valve is located inside the cylindrical box (3). Make sure that the two fins (4) of the valve are correctly positioned in the grooves provided inside the cylindrical box. For proper operation, the “forks” (5) must be present and the white cap (6) correctly installed.

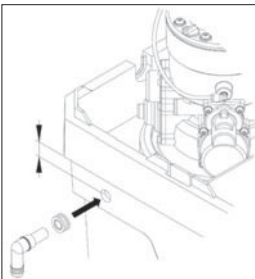
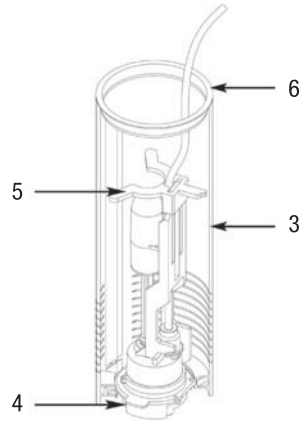
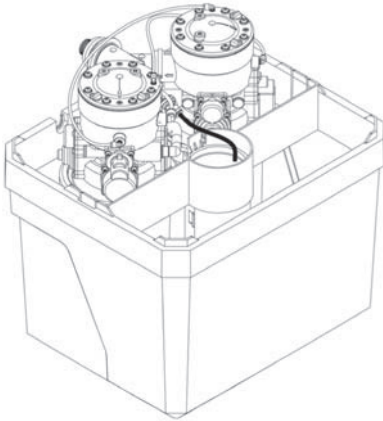

CAUTION!

Do not use strong oxidisers inside the brine container (bleach, etc.).

Install the overflow elbow (included). Insert the gasket into the 15 mm hole and fit the elbow hose holder. Then connect the drain. Do not connect the overflow drain to the softener drain.

INSERTION OF THE “Y” CONNECTION

- Grease the gaskets of the Y connections and the inside of the body for easy assembly.

It is necessary to first insert the clips at the bottom and then those at the top to avoid deforming them.

- Follow the numbering for correct assembly.

- Check that all clips are correctly secured and do not come out of their seats (to guarantee seal when the softener is pressurised).

The Y connections are already installed in the DLT56A models.

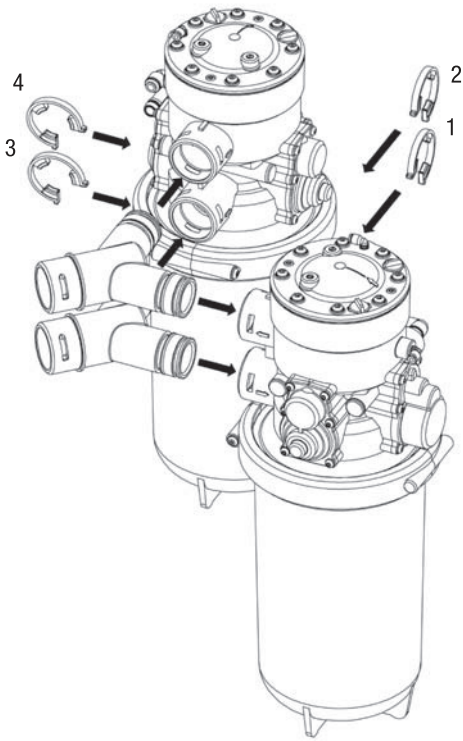

DRAIN PIPES CONNECTION

The drain pipe must have a minimum internal diameter of 12 mm



Use only reinforced drain pipes to avoid obstructions

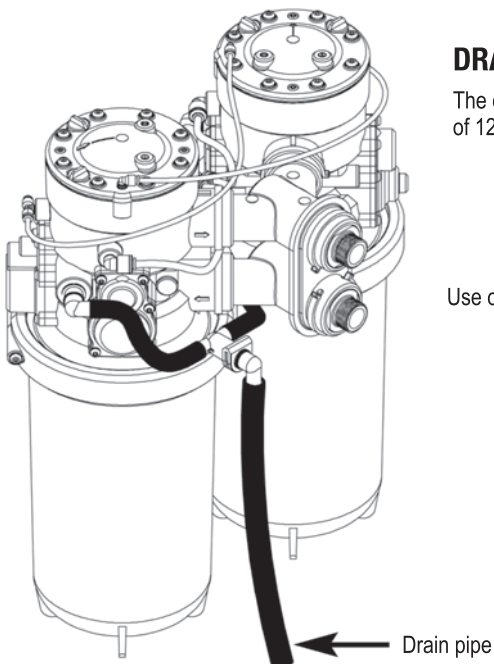
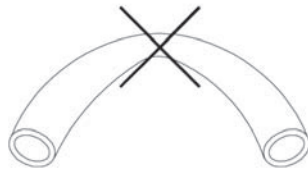

BRINE PIPES CONNECTION

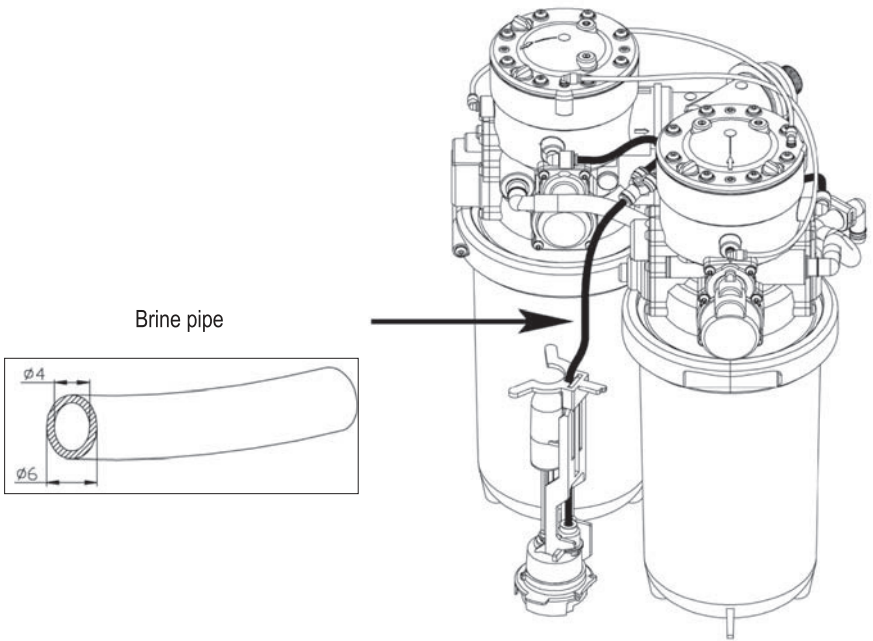

COMMUNICATION PIPES CONNECTION

The communication pipes (only for DLT56A models) and the brine pipes are pre-installed on all models.

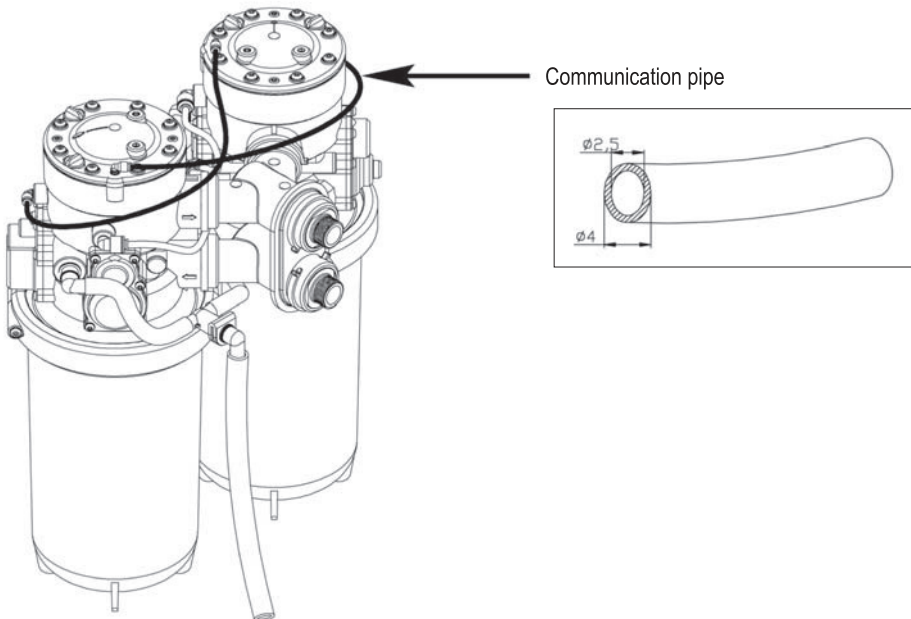

BY-PASS

- standard for the DLT54A model

- optional for the DLT56A model

The by-pass is used to easily and quickly exclude the softener from the mains water. It also allows the adjustment of the water residual hardness. When the reference arrow (no. 1) of the by-pass valve is oriented towards "S - service", the hard water entering the by-pass is conveyed into the softener and comes out softened; when the arrow is oriented towards "bypass", the hard water goes directly to the outlet, thus making it possible (after having depressurised it) to disconnect the softener from the by-pass.

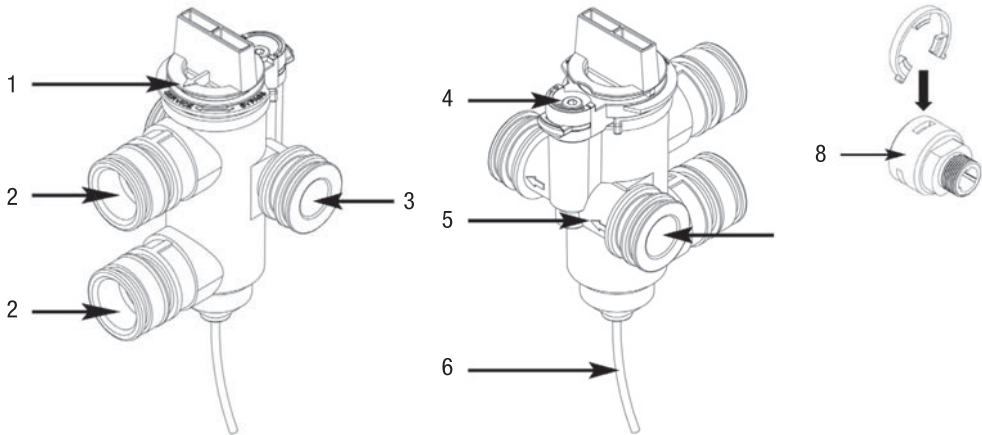

1. Flow reference arrow
2. Connections to softener
3. By-pass outlet
4. Screw for residual hardness adjustment

5. Direction arrow
6. Communication pipe (diam. 4 mm - mod. DLT54A)
7. By-pass inlet
8. By-pass connection

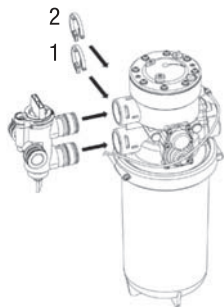

BY-PASS installation in DLT54A model (included), follow the numbering for correct assembly

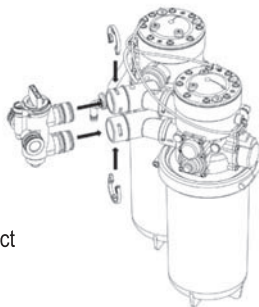

BY-PASS installation in DLT56A model (optional)

ADJUSTMENT OF RESIDUAL HARDNESS

The residual hardness can be adjusted using the adjustment screw (4). The by-pass is supplied with the hardness screw closed to obtain about 0°f at the outlet. To increase the residual hardness, turn the screw anti-clockwise with a screwdriver (towards the "°" symbol). Then open a valve, let a little water run and test the residual hardness of the water; adjust the desired hardness accordingly using the screw.

CAUTION: Never turn the by-pass valve (from service to bypass or vice-versa) or adjust the residual hardness during service or regeneration. For these operations, it is necessary to close the main water valve before intervening.

INSTALLATION LOCATION

It is recommended to install the EURODLT softeners in clean and healthy environments. For residential applications, the softener is normally installed after the metre.

The environmental temperature must always be above 5°C to prevent frost.

The drain pipes must not have restrictions and twisting.

In order to avoid an excessive pressure return on the softener discharge valve, the length of the drain pipe must not exceed the following measurements:

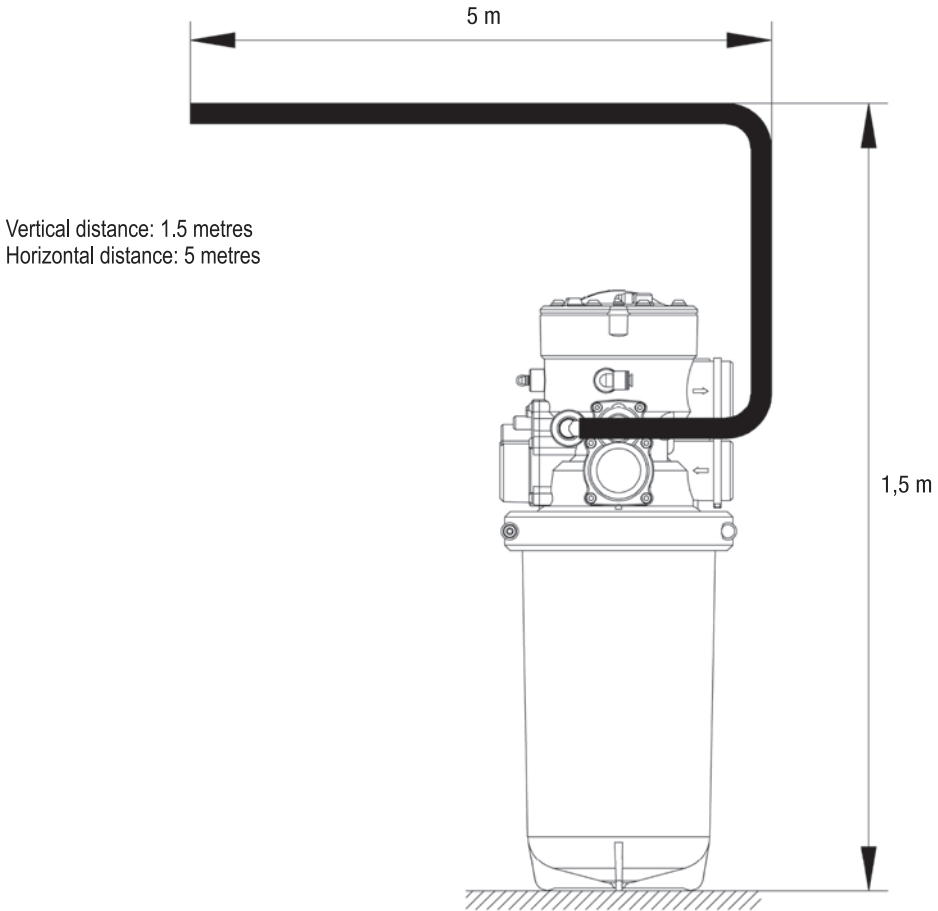

- Should it be necessary to increase the horizontal distance, run the softener drain into a normal PVC drain, thus covering the required distance.
- If the vertical distance is too much (more than 1.5 m), the softener can be raised on normal wall supports.
- Do not connect the softener drain pipe directly to a drain, sewer or sump. Always provide an air vent (opening) between the pipe and the drain to prevent returns and contamination.
- Do not connect the softener drain pipe with the overflow pipe to avoid the backflow of water into the salt container.

PREPARING THE SOFTENER FOR THE FIRST REGENERATION

PREPARING THE BRINE

1. The EURODLT softener is (by default) ready for the production of softened water; however, the brine must be prepared for the first automatic regeneration.

In the DLT56A model, check that the white cap on the cylindrical box containing the brine valve is correctly positioned to prevent salt falling in. Fill with salt as shown in the drawings below. The brine valve must not have pieces of salt in contact because they could block its function.



2. Slowly add tap water until the brine valve float rises by 2 cm. The brine valve can be inspected inside the brine container behind the salt separator by lifting the white oval cap on the left for the DLT54A model or inside the cylindrical box by lifting the white round cap for the DLT56A model (images on page 9).

The required amount of water is about 10 litres for the DLT56A model and about 7 litres for the DLT54A model (approximate values depending on the size of the salt tabs), but it is important for the float to “float” by about 15 mm.

Always refit the covers on the salt containers to limit the evaporation of the brine. Never let the salt level drop below 1/3 of the container during use; for optimal operation, keep the salt level above the water level.

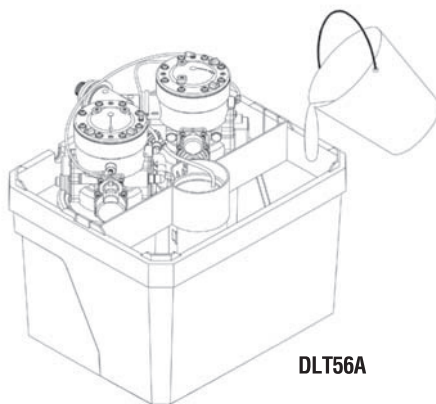
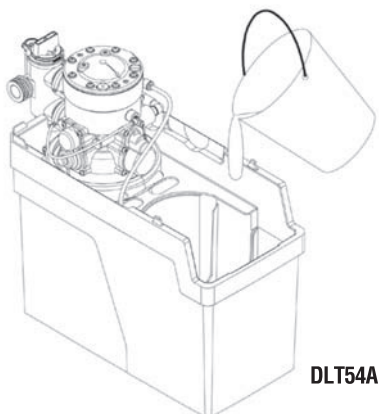

INLET WATER HARDNESS ADJUSTMENT

3. Measure the inlet water hardness. Convert to ppm and adjust the hardness setting disc on the reference arrow, turning the yellow screw using a 4 mm flat-head screwdriver.

1°f = 10 ppm CaCO₃

4. If the reference arrow is not at “S” (service) of the program position indicator, manually place it at “S” by turning the black screw using a 4 mm flat-head screwdriver (see images below).

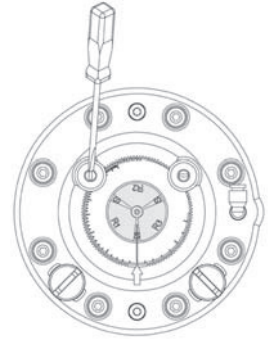
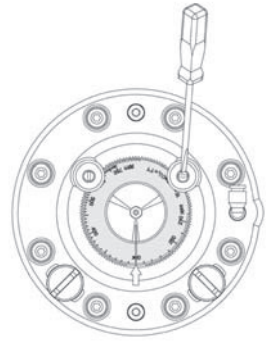

TOP VIEW OF THE CONTROL HEAD

BLACK AXIS FOR THE MANUAL LAUNCH OF REGENERATION

SCALE FOR SETTING THE HARDNESS

YELLOW AXIS FOR SETTING THE HARDNESS

PROGRAM POSITION INDICATOR

INDICATOR DISC OF THE RESIDUAL AUTONOMY LITRES

REFERENCE ARROW

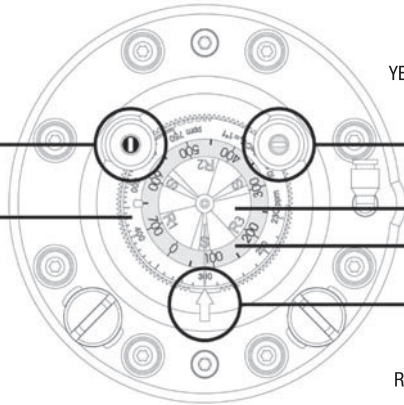

Looking at the technical drawing as a practical example, the softener is in service (line on “S”). It is calibrated for inlet water with a hardness of 30°C (line on 300 ppm) and still has a residual autonomy of 200 litres before the next automatic regeneration (line on 200).

DLT56A INSTALLATION WITH BY-PASS

Max inlet pressure: 6 bar (static pressure)

Min inlet pressure: 2 bar (dynamic pressure)

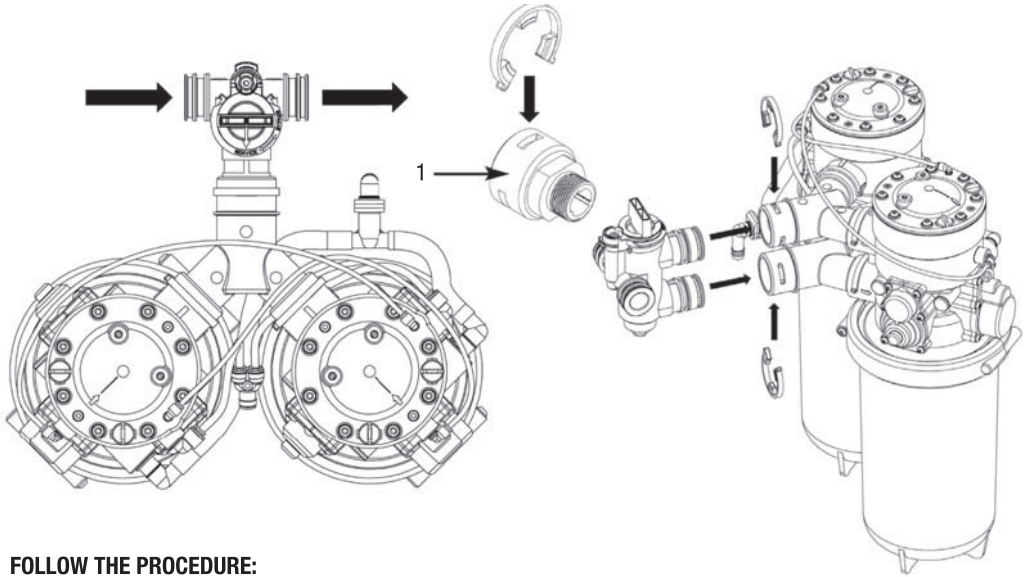

FOLLOW THE PROCEDURE:

1. Adjust the inlet water hardness and prepare the brine as described on pages 15 and 16.
2. Connect 2 flexible hoses to the mains and connect them on the 2 by-pass connections (1).
3. Grease the by-pass o-rings (with food grade silicone grease) and insert it into the Y connections of the softener, then secure it with the clips, snapping them to the bottom of their seat (see drawing above).
4. Insert the by-pass connections (with flexible hoses already tightened) into their seat and secure them with the appropriate clips, taking care to respect the water flow direction (see drawing above and page 13).
5. Connect the grey drain pipe (page 11) and connect it to the drain. Separately connect the overflow elbow to the drain (see page 10). Check that the communication pipes and the brine pipe (page 12) and correctly installed.
6. Leaving the by-pass in By-pass position (as supplied), slowly open the inlet water and let a little water run from a tap and check for any water leaks from the connections.
7. Close the inlet water, drain discharge the system pressure and turn the by-pass knob 90° clockwise until the arrow is positioned at "SERVICE" (drawing on page 13).
8. Slowly open the inlet water again and check for any leaks.

At the end of these operations, the softener will be ready to deliver completely softened water. However, it is advisable to perform a regeneration as described on page 20.

If the residual hardness of the water is to be adjusted, refer to page 13.

INSTALLATION OF DLT56A TO AN EXTERNAL BY-PASS SYSTEM

Max inlet pressure: 6 bar (static pressure)

Min inlet pressure: 2 bar (dynamic pressure)

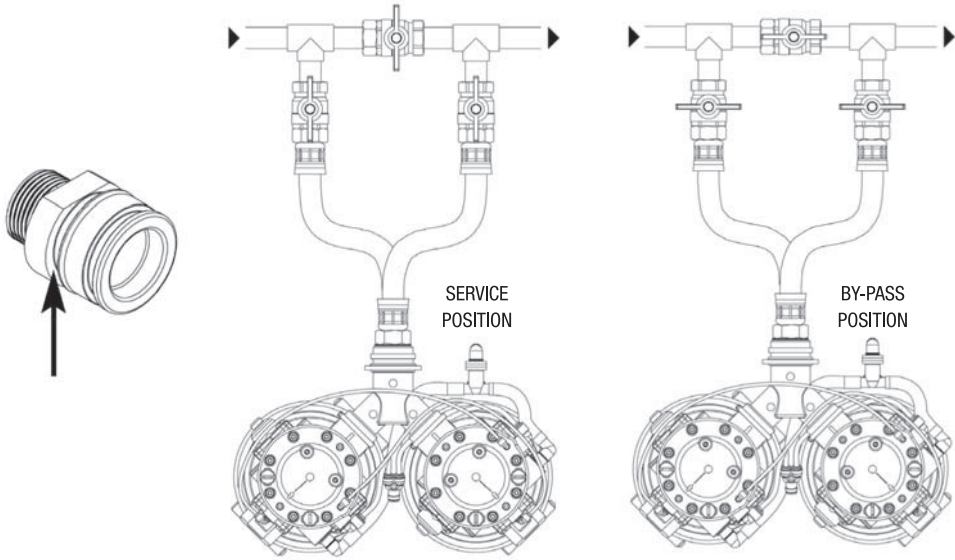

If you do not want to use the softener by-pass it can be connected to the main via the available connections (1) with 3/4" (standard) or 1" (on request) threads, creating a classic by-pass with three closing valves (see above). In this case, it will not be possible to have outlet residual hardness through the softener.

FOLLOW THE PROCEDURE:

1. Adjust the inlet water hardness and prepare the brine as described on pages 15 and 16.
2. Assemble the 3-valve by-pass and connect it to the water supply. Position the three valves in "by-pass" position as shown in the figure to the right. Let a little water run from a tap to eliminate any processing swarf in the pipes and check for any water leaks from the connections.
3. Tighten the two flexible hoses on the connections, grease the o-rings with food grade silicone grease and insert them in the "Y" connections of the softener. Then fix the connections with the clips, snapping them to the bottom of their seat to prevent them coming out when the softener is pressurised.
4. Install the grey drain pipe (page 11) and connect it to the drain. Separately connect the overflow elbow to the drain (see page 10). Check that the communication pipes and the brine pipe (page 12) and correctly installed.
5. Then turn the three valves to service position as shown in the left figure, being careful to slowly open the water inlet. Make sure there are no leaks.
6. At the end of these operations, the softener will be ready to deliver completely softened water.

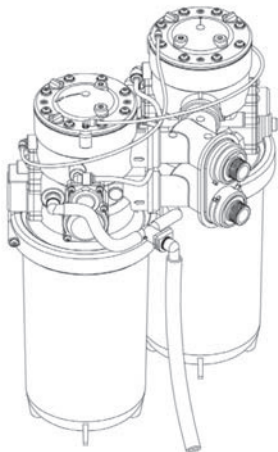

However, it is advisable to perform a regeneration as described on page 20.

INSTALLATION OF DLT54A

FOLLOW THE PROCEDURE:

1. Adjust the inlet water hardness and prepare the brine, see pages 15 and 16.
2. Grease the by-pass o-rings with food grade silicone grease and insert it into the body of the softener valves, then secure it with the clips, snapping them to the bottom of their seat. For easier assembly, first insert the bottom clips (page 13).
3. Connect 2 flexible hoses to the mains and connect them on the 2 by-pass connections.
4. Insert the by-pass connections (with flexible hoses already tightened) into their seat securing them with the appropriate clips, taking care to respect the water flow direction, see drawings on pages 13 and 17.
5. Connect the grey drain pipe (page 11) and connect it to the drain. Also connect separately from the first, the overflow elbow to the drain (page 10). Install the signal tube to the by-pass (no.6 page 13) in the body fitting (no.7 page 8), taking care to insert it properly into the quick insert (pushing it until it clicks).
Check that the brine pipe (page 12) is correctly installed.

6. Leaving the by-pass in by-pass position (as supplied), slowly open the inlet water and let a little water run from a tap to eliminate any processing swarf in the pipes and check for any water leaks from the connections.

7. Close the inlet water, drain discharge the system pressure and turn the by-pass knob 90° clockwise until the arrow is positioned at "service" (drawing on page 8)

8. Slowly open the inlet water again and check for any leaks.

At the end of these operations, the softener will be ready to deliver completely softened water. However, it is advisable to perform a regeneration as described on page 20.

If the residual hardness of the water is to be adjusted, refer to page 13.

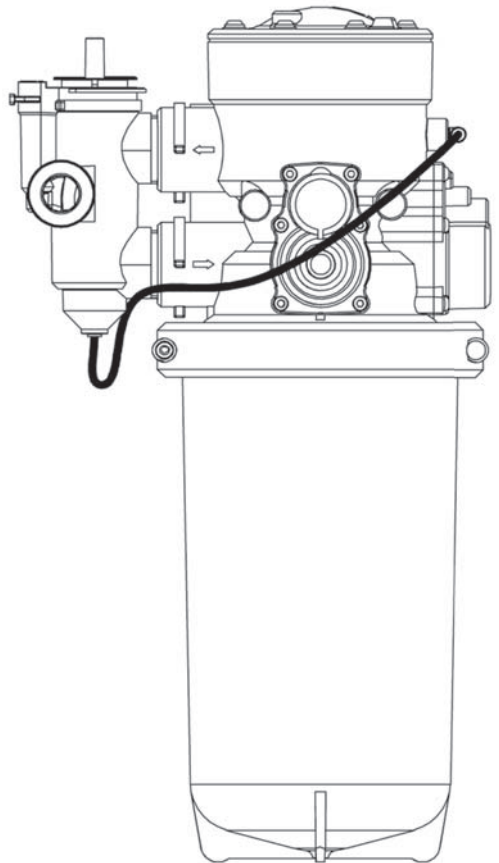

Max inlet pressure: 6 bar (static pressure)
Min inlet pressure: 2 bar (dynamic pressure)

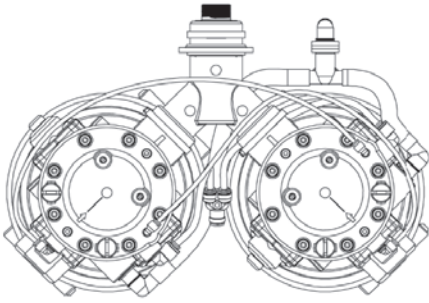

BEGINNING OF A REGENERATION

It is appropriate to perform a softener regeneration after its installation to check that the appliance is working properly. The regeneration of a module lasts approximately 12-15 minutes.

CAUTION: with the DLT56A model in automatic operation, it is possible that the two modules regenerate at the same time: be careful not to manually force the regeneration of the two modules at the same time (otherwise the softener will block the water outlet).

A manual regeneration is initiated by simply turning the black screw on the control head clockwise by half a turn with a screwdriver (page 16 point 4). The regeneration will proceed automatically as follows:

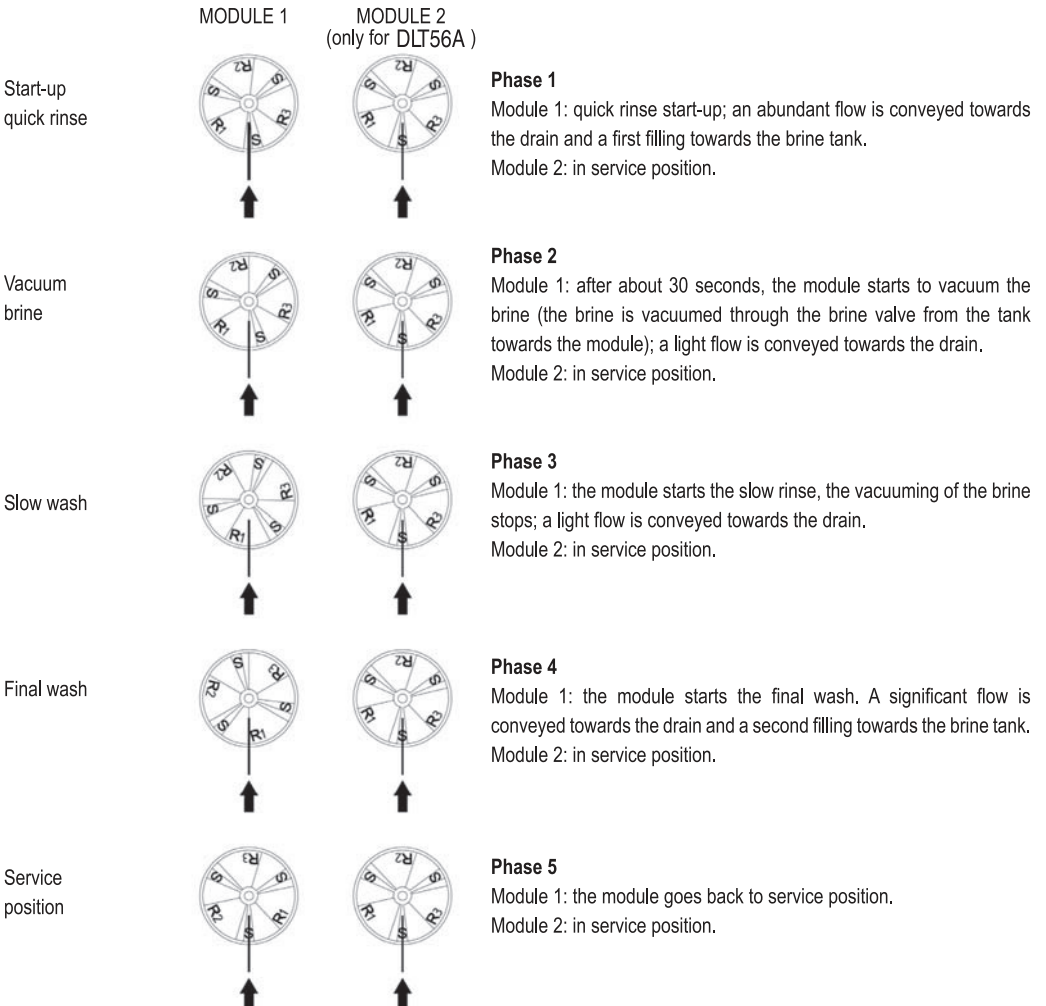

For the DLT56A softener, perform the same procedure on module 2 (right module). If both modules are erroneously set to “R”, turn the two internal discs to “S” as described on page 16 point 4.

DISINFECTION WITH CITRIC ACID

To maintain and ensure good softener operation and performance, it is advisable to provide for appliance cleaning and disinfection with citric acid at least once a year, as follows:

- Dissolve 50 grams of citric acid in about 700 ml of hot water in a one litre bottle (do not fill the bottle because when cleaning starts, the softener will add water in the bottle).
- Disconnect the brine valve (page 9) by pressing the quick coupling manual release button and removing the 6 mm connection pipe (page 22).
- Insert a 6 mm pipe (like that of the brine valve) into the quick coupling, making sure to hear the coupling click and place it inside the bottle with the previously prepared solution.
- Manually set the appliance in manual regeneration by simply turning the black screw on the control head by half a turn clockwise (pages 16 and 20).
- The softener will add water (about 250 ml) for about 30 seconds during the quick rinse phase and then it will start the vacuuming phase. Have the citric acid solution manually vacuumed through the 6 mm pipe.
- To prevent vacuuming too much air, as soon as the solution is vacuumed, disconnect the pipe and reconnect the brine valve pipe, taking care to insert it all the way into the quick coupling, making sure that it clicks into place. An incorrect connection of the brine valve can cause leaks and the softener to malfunction.
- The softener will automatically clean, disinfect and regenerate the module. Wait the end of the regeneration (about 15 minutes from the beginning of the operation) and check for any leaks between the brine valve pipe and the quick coupling.
- The softener is ready for use.

In case of an DLT56A model, perform the previously described operations on both modules.

PIPE CONNECTION/DISCONNECTION

CONNECTION

The connection to the quick coupling must be manually done by pushing the pipe on its axis (1). Try pulling the pipe backwards to make sure that connection is correct (2).

Step 1

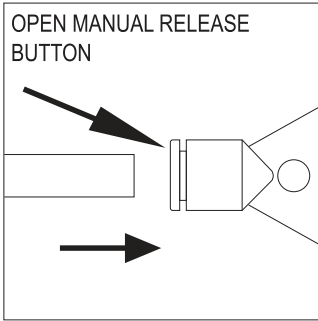

Step 2

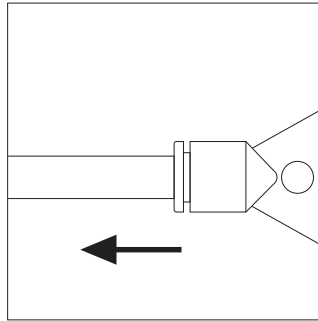

DISCONNECTION

After pressing the manual release button (1), remove the pipe by pulling it on the quick coupling axis while keeping the release button pressed (2-3).

Step 1

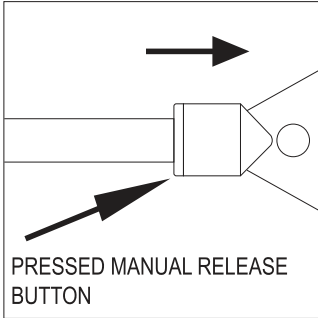

Step 2

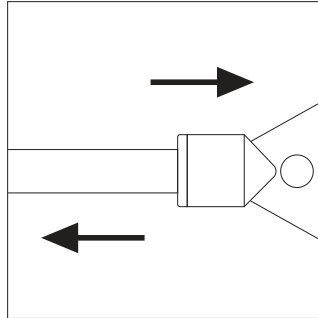

Step 3

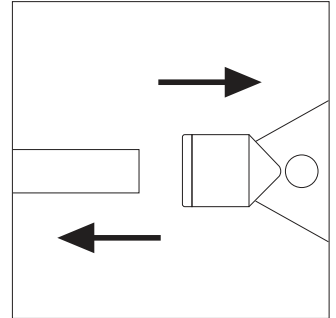

MAINTENANCE MANUAL

ROUTINE MAINTENANCE

This equipment requires regular periodic maintenance in order to ensure the potability requirements of treated drinking water and the maintenance of improvements as declared by the manufacturer.

The appliance requires normal attention during operation and reintegration of the salt in the brine vat when this is almost finished.

EXTRAORDINARY MAINTENANCE

To ensure proper operation of the ARCHIMEDE system, it is necessary to perform the following annual checks:

1. Cleaning and washing of the brine valve and salt vat with warm water.
2. Softener disinfection with citric acid (page 21).
3. Inspection of the drain pipe along its entire length to check that the water flow is not reduced.

Space for notes on maintenance

Date	Type of Intervention:
Date	Type of Intervention:
Date	Type of Intervention:
Date	Type of Intervention:
Date	Type of Intervention:

WARRANTIES

Preserve the box label in order to identify the product.

The applied warranty terms are those contained in EEC Directive 85/374 for EU Countries. For countries outside of the EU, the product is covered by limit warranty for 12 months from the date of purchase, as proven by regular sales receipt. Requests for reimbursement must be sent in written form to the sales outlet Room8-i, Shengquang building, No.28, Tanjiadu Road, Shanghai.

The damaged party must indicate the product, place and date of purchase, offer to provide the product and prove the relationship between defect and damage. For any controversy, the manufacturer chooses the Padua Courts Jurisdiction in Italy and the applicable laws shall be Italian.

EURODLT



Address : Room8-i,Sheng Quan building, No.28, Tanjiadu Road, Shanghai
Tel: 400 869 8977